



## **CNC VERTICAL LATHE** (HIGH SPEED Series)

---

TKV - 460H / TKV - 760H  
TKV - 860H / TKV - 1100H

TWIN MACHINE (T) & MILLING FUNCTION (M)  
ALSO AVAILABLE

**CNC-TAKANG**

**CNC-TAKANG CO., LTD.**  
MANUFACTURER & EXPORTER

**High Speed Series**  
**VT**

# TKV-460H Series



**TKV-460H  
with V4 turret (Option)**



**TKV-460HT  
Twin type with  
H12+H12 turrets**

# TKV-760H / 860H / 1100H Series



**TKV-760H**  
with V4 / V6 turret (Option)



**TKV-860HM**  
with H12  
milling turret



**TKV-1100H**

# TKV-460H / 760H / 860H / 1100H

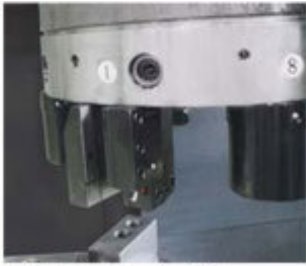

H12 Turret with milling  
(Turning)



H12 Turret



H12 Turret (Drilling)



Air condition for electrical  
cabinet



Special chuck (Options)

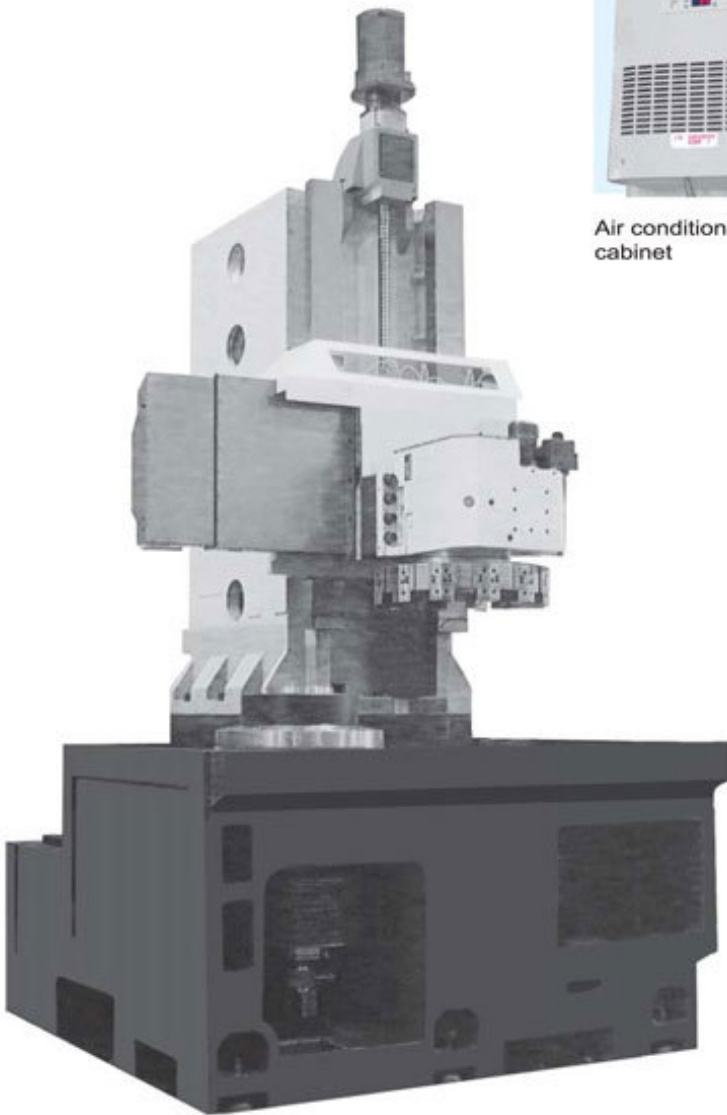

V6 Turret



V4 Turret

## ■ OPTIONS



Second control box



Coolant system  
(3 bar and more)



High and low pressure  
of hydraulic chuck



Tool presetter



Oil mist collector



External counter for  
each insert

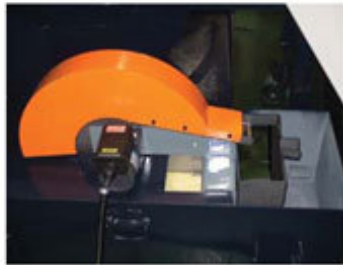

Oil skimmer (Disk type)



High torque main  
spindle motor with  
built-in dual speed  
gearbox



Finger hydraulic chuck



Simultaneous double  
tooling device

# TKV-460H / 760H / 860H / 1100H

## Table-speed & torque

**TKV-460H Series,  $\alpha$ ip 18.5/22kw**

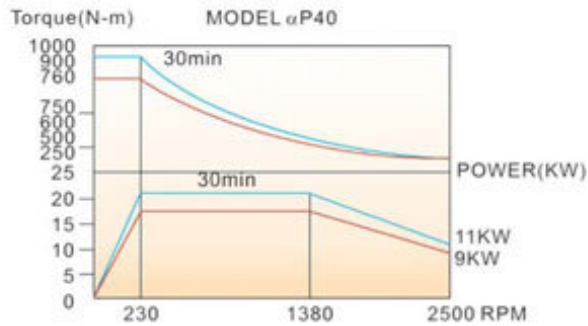

**TKV-760H Series,  $\alpha$ ip 18.5/22kw, 2 Steps**

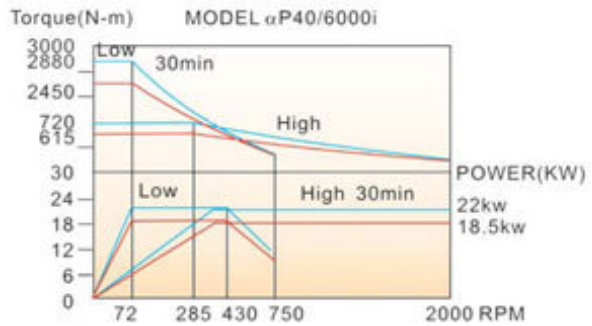

**TKV-760H Series,  $\alpha$ ip 30/37kw, 2 Steps**

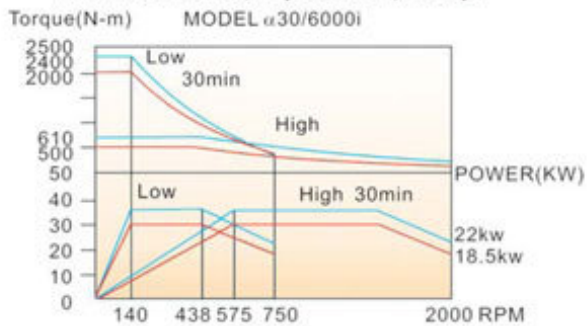

**TKV-860H Series,  $\alpha$ ip 18.5/22kw, 2 Steps**

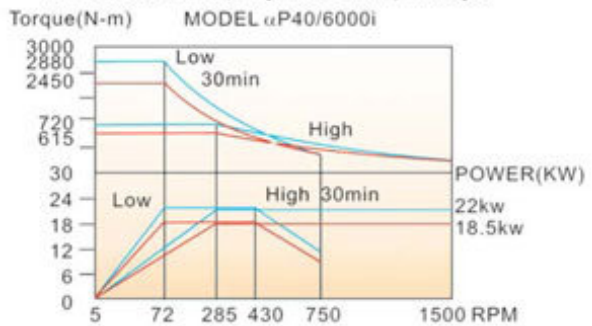

**TKV-860H Series,  $\alpha$  30/37kw, 2 Steps**

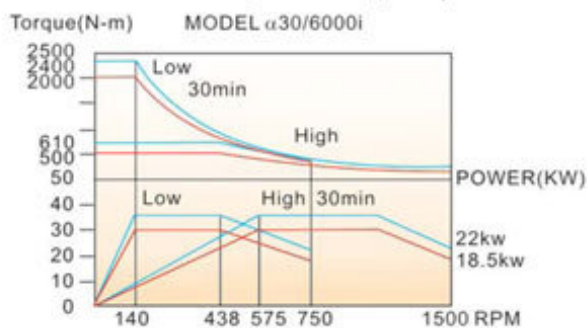

**TKV-860H Series,  $\alpha$  37/45kw, 2 Steps**

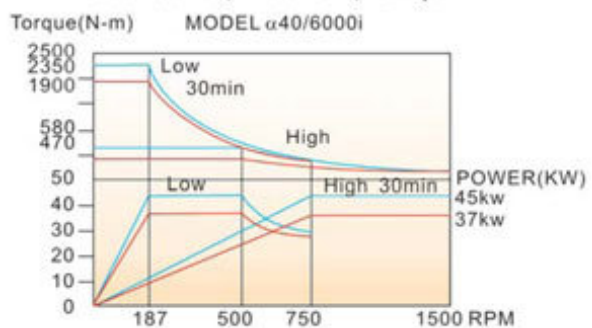

**TKV-1100H Series,  $\alpha$  37/45kw, 2 Steps**

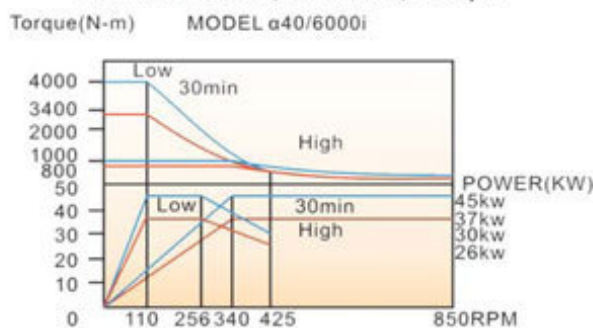

**TKV-1100H Series,  $\alpha$  45/55kw, 2 Steps**

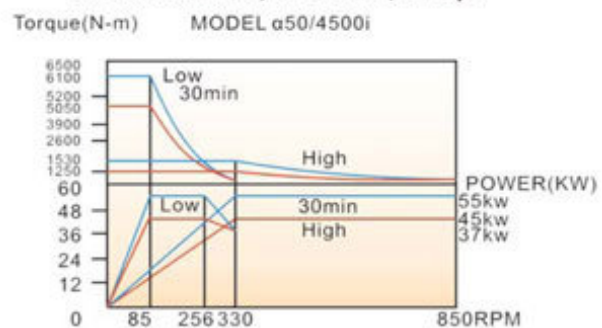

# TKV-460H / 760H / 860H / 1100H

## ■ DIMENSIONS (Unit: mm)

### TKV-460H Series

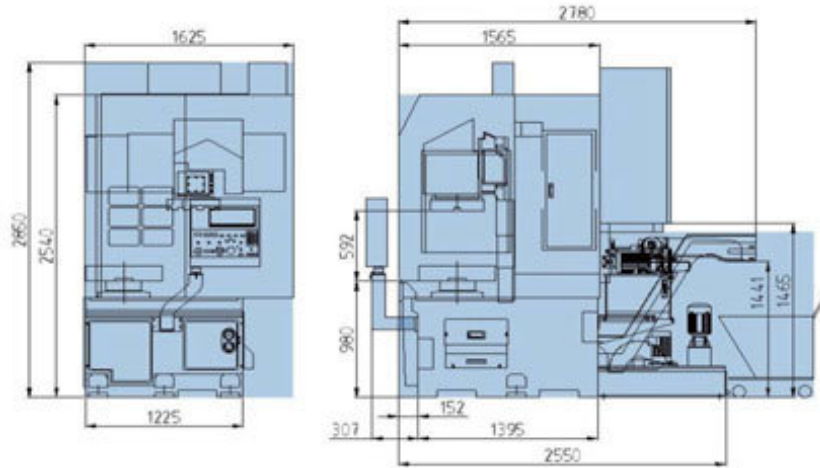

### TKV-760H Series

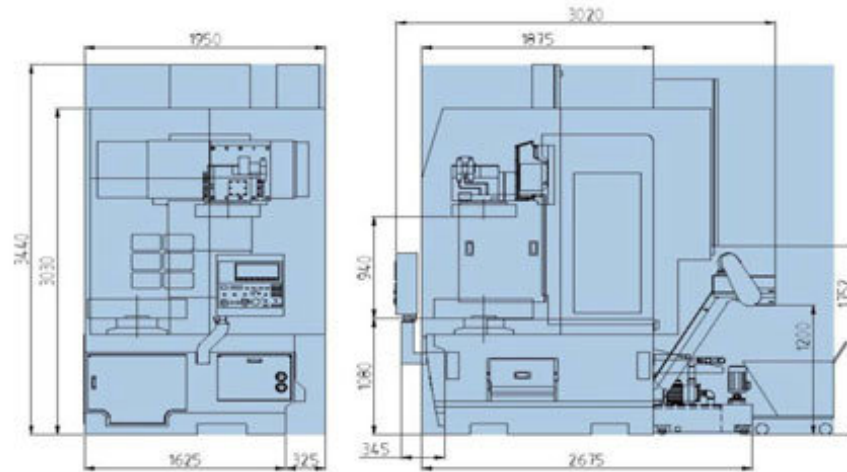

### TKV-860H Series

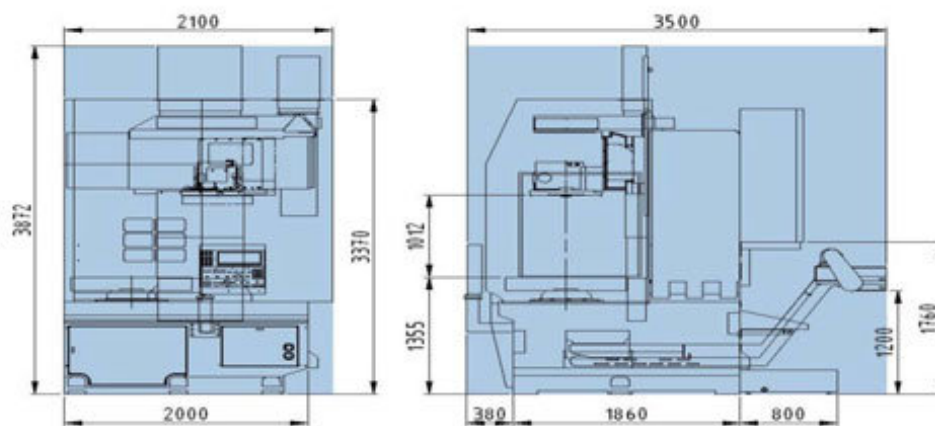

**TKV-1100H Series**

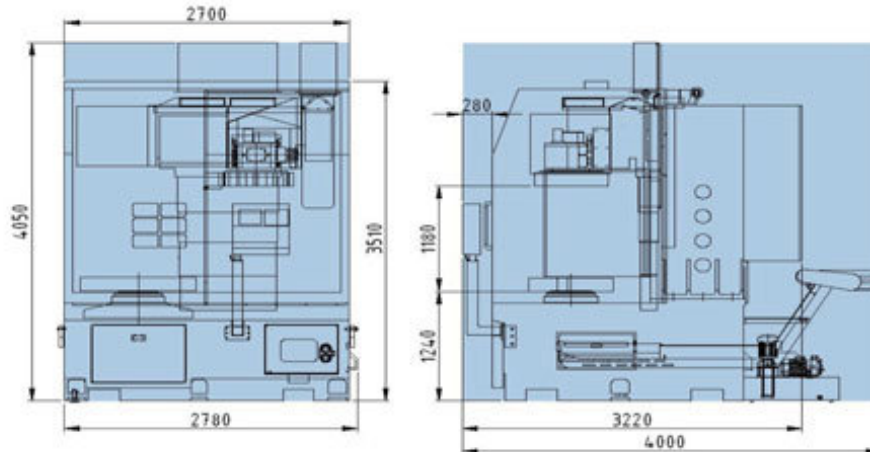

**STANDARD TOOLING SYSTEM (For H12 TURRET) (Unit: mm)**

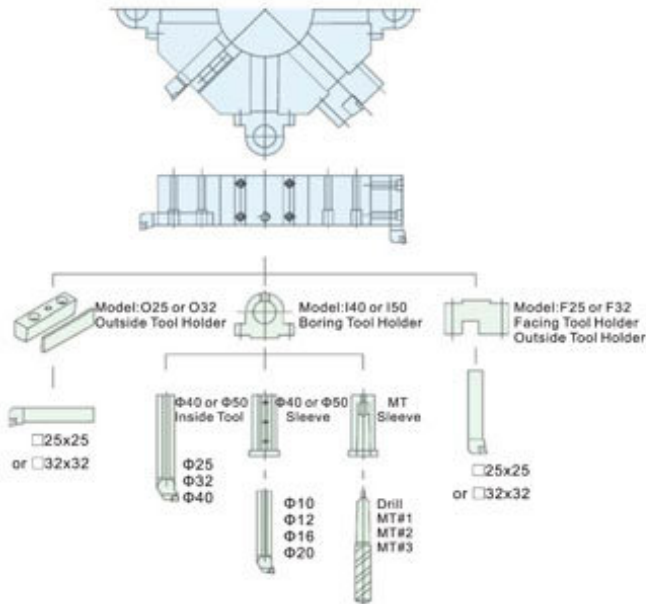

**ELECTRICAL CABINET**



- Easy maintenance circuit arrangement.
- Suitable all kinds of environment.
- CE standard available.

**CNC CONTROLLER**



Fanuc 0i-T



Siemens 802D



Siemens 840D



■ WORK RANGE: H12 TURRET (Unit: mm)

TKV-460H

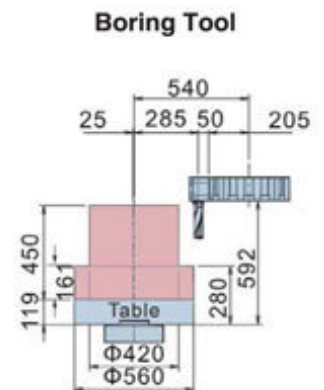
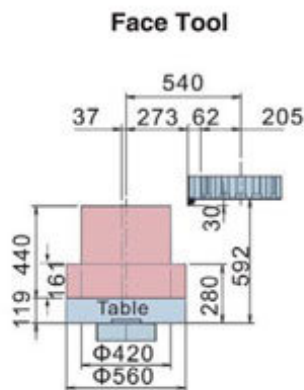
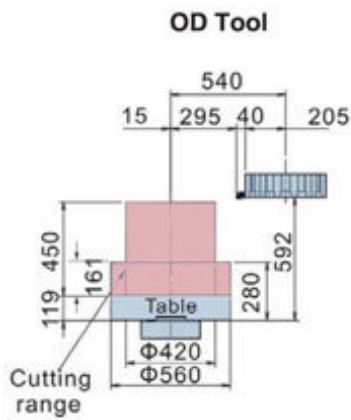

TKV-760H

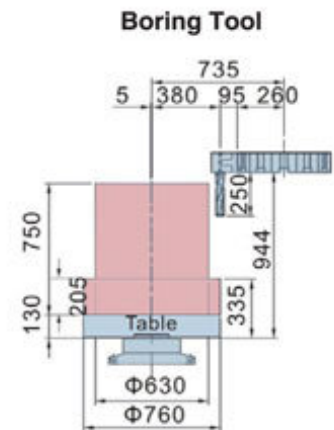
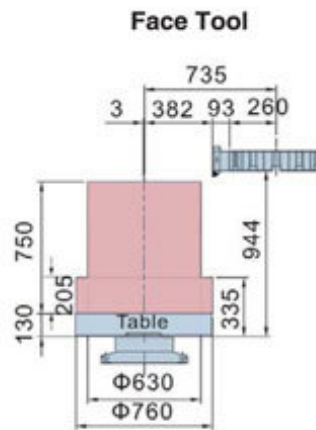
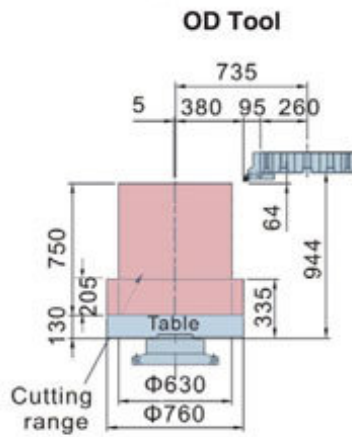

TKV-860H

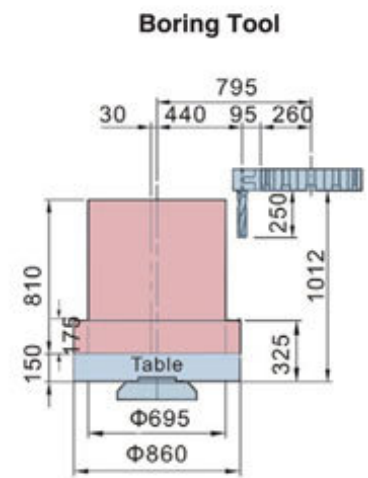
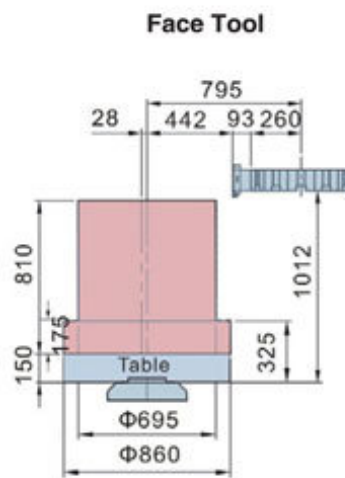
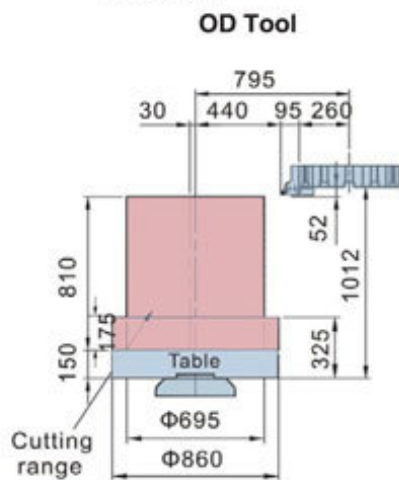

# TKV-460H / 760H / 860H / 1100H

## TKV-1100H

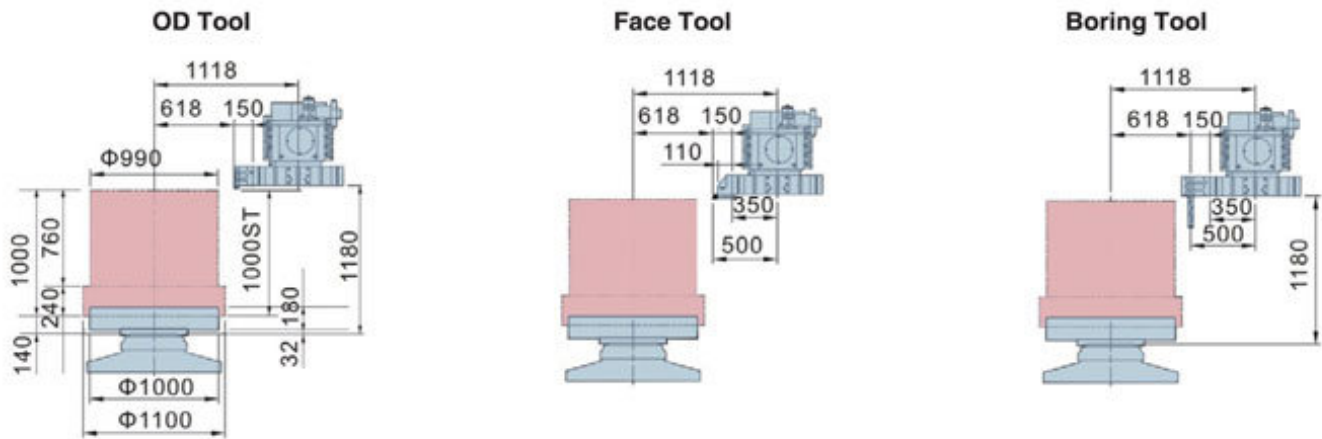

## ■ TOOL INTERFERENCE: H12 TURRET (Unit: mm)

### TKV-460H (H12)

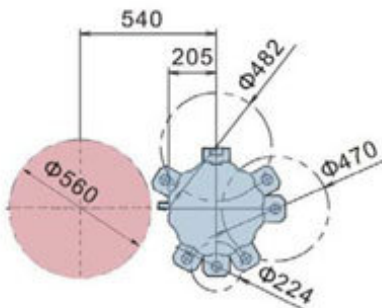

### TKV-760 (H12)

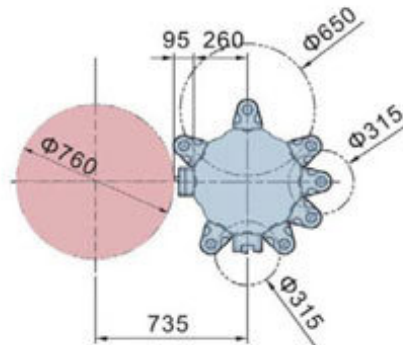

### TKV-860H (H12)

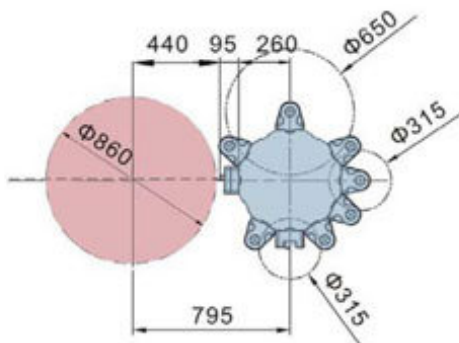

### TKV-1100H (H12)

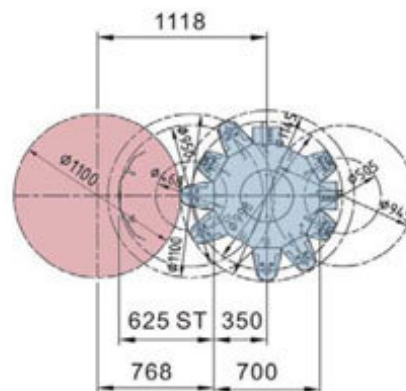

# TKV-460H / 760H / 860H / 1100H Series

## SPECIFICATIONS

MODEL	DESCRIPTION	TKV-460H	TKV-460HT	TKV-460HM	TKV-460HMT	TKV-760H	TKV-1100H	
Capacity	Max. swing dia.	560 mm (650 mm, V-type turret only)					800 mm	
	Max. turning dia.	460 mm					760 mm	
	Std. turning dia.	460 mm					760 mm	
	Max. turning height	450 mm (350 mm, V-type turret only)		380 mm			750 mm (620 mm, V-type turret only)	
Spindle	Hydraulic chuck	305 mm (12")						
	Range of table speed	25-2500 rpm						
	Front bearing dia.	120 mm						
	Spindle nose	A2-8						
Turret	Turret type	H12 (OPT V4 / V6 / V8)	H12+H12	H12	H12+H12	H12 (OPT V4 / V6 / V8)	H12 (OPT V4 / V6 / V8)	
	Number of tool position	12 (OPT 4 / 6 / 8)	12+12	12	12+12	12 (OPT 4 / 6 / 8)	12 (OPT 4 / 6 / 8)	
	Tool Size	□25, □32, Ø 40 mm		□25, Ø 40 mm		□25, □32, Ø 40, Ø 50 mm		
Feed	Rapid rate (X-axis)	20 M/min						
	Rapid rate (Z-axis)	20 M/min						
	Horizontal travel (X-axis)	310 mm (-10 + 310 mm, V-type turret only)					385 mm (-10 + 385 mm, V-type turret only)	
	Vertical travel (Z-axis)	460 mm (550 mm, V-type turret only)					760 mm	
	Cutting federate	0.001-500 mm/min						
	Feed override	0-150 %						
Motor	Controller system	FANUC 0i-T						
	Spindle motor (Cont./30min)	18.5 / 22 kw (ap40)						
	Feed motor (X-axis)	3 kw						
	Feed motor (Z-axis)	4 kw (7 kw, V-type turret only)					7 kw	
	Driving tool motor (Cont./30min)			3.7 / 5.5 kw				
Miscellaneous	Power requirement	40 KVA	75 KVA	45 KVA	85 KVA	40 KVA	75 KVA	
	Floor space (L x W, mm)	1700 x 3100	3400 x 3100	1700 x 3100	3400 x 3100	1950 x 3410	3900 x 3410	
	Max. height	2855 mm						
	Net weight	6500 kgs	13000 kgs	6600 kgs	13200 kgs	11500 kgs	23000 kgs	

※THE SPECIFICATIONS ARE SUBJECT TO CHANGE WITHOUT PRIOR NOTICE.

### ■STANDARD ACCESSORIES:

- Spindle orientation.
- Manual 3-jaw chuck (for TKV-1100H).
- Hydraulic 3-jaw solid chuck & cylinder, size as spec (except TKV-1100H).
- Hydraulic power unit.
- Soft jaw x 1 set for hydraulic chuck (except TKV-1100H).
- Foot switch for hydraulic chuck (except TKV-1100H).
- Tool holder (as turret numbers).
- Automatic lubrication system.
- Coolant through tool holder to inserts.
- Coolant flushing system with tank.
- Protection door.
- Heat exchanger for electrical cabinet.
- Full enclosed splash guard.
- Work light.
- Warning light (R / Y / G).
- Workpiece counter (CNC Controller).
- Chain type chip conveyor & chip trolley.
- Manual for operation & maintenance.
- Manual for electrical & hydraulic circuit diagram.
- Manual for controller.
- Tool box with tool kits.
- Leveling bolts & pads.

TKV-760HT	TKV-760HM	TKV-760HMT	TKV-860H	TKV-860HT	TKV-860HM	TKV-860HMT	TKV-1100H	TKV-1100HM
(850 mm, V-type turret only)			1000 mm				1320 mm	
740 mm		860 mm			850 mm		1100 mm	
740 mm		860 mm			850 mm		1000 mm	
690 mm		810 mm (800 mm, V-type turret only)			760 mm		925 mm	910 mm
457 mm (18")			533 mm (21")				1000 mm (40")	
25-2000 rpm			25-1500 rpm				5-850 rpm	
160 mm			200 mm				200 mm	
A2-11			A2-11 (OPT A2-15)				ISO 702-4 No.15 (Ø 380 mm)	
2+H12	H12	H12+H12	H12 (OPT V4 / V6 / V8)	H12+H12	H12	H12+H12	H12	
2+12	12	12+12	12 (OPT 4/6/8)	12+12	12	12+12	12	
50 mm	□25, Ø 40, Ø 50 mm		□25, □32, Ø 40, Ø 50 mm		□25, Ø 40, Ø 50 mm		□32, Ø 50 mm	
20 M/min			20 M/min				20 M/min	
20 M/min			20 M/min				20 M/min	
50 + 550 mm, V-type turret only)			470 mm (-50 + 550 mm, V-type turret only)				625 mm	
(700 mm, V-type turret only)			860 mm (850 mm, V-type turret only)				1000 mm	
0.001-500 mm/min			0.001-500 mm/min				0.001-500 mm/min	
0-150 %			0-150 %				0-150 %	
FANUC 0i-T			FANUC 0i-T				FANUC 0i-T	
18.5 / 22 kw (ap40)			18.5 / 22 kw (ap40)				37 / 45 kw (α40)	
4 kw			4 kw				4 kw	
(4 kw, V-type turret only)			7 kw (4 kw, V-type turret only)				7 kw	
7.5 / 11 kw			7.5 / 11kw				7.5 / 11 kw	
5 KVA	45 KVA	85 KVA	40 KVA	75 KVA	45 KVA	85 KVA	80 KVA	
1950 x 3410	1950 x 3410	3900 x 3410	2100 x 3500 (V-type turret only 1950 x 3500)	4200 x 3500	1950 x 3500	4200 x 3500	2700 x 4000	
3450 mm			3900 mm				4050 mm	
100 kgs	11600 kgs	23200 kgs	14500 kgs (V-type turret only 14600 kgs)	29000 kgs	14600 kgs	29200 kgs	21000 kgs	21800 kgs

## ■ OPTIONS:

- Higher power motor, α i30 (30/37kw) , α i40 (37/45kw), α i 50 (45/55kw).
- Extra hydraulic chuck & cylinder.
- Dual speed gear box for driving tool spindle.
- High & low pressure chucking.
- Chuck position sensor.
- Hard jaw of chuck.
- CNC controller FANUC 18i-T series.
- Manual guide i.
- Oil mist collector.
- Auto door (Automatic opening & closing of main door).
- Simultaneous double tooling devices.
- Special tool holder.
- High pressure coolant through turret.
- Tool presetter with cover protection.
- Turning tools.
- External counter display for each insert.
- Air condition for electrical cabinet.
- Oil skimmer (Disk type).
- Scrap type chip conveyor with chip trolley.
- Jig & fixture.
- Turnkey project.
- External power transformer.
- CE mark.

## CNC-TAKANG CO., LTD.

No. 72, Alley 7, Lane 98, 1st Road, Taichung Industry Park,  
Taichung 40767, TAIWAN  
FAX: +886-4-2359 6064 E-mail: takang@ms17.hinet.net  
TEL: (04)2359 6056 Web site: www.cnctakang.com.tw