



O
O
O
-
C
M
H

HORIZONTAL MACHINING CENTER

HMC-500A / HMC-500B

- *ECONOMICAL*
- *HIGH EFFICIENCY*

CNC-TAKANG

CNC-TAKANG CO., LTD.
MANUFACTURER & EXPORTER

HMC-500A / 500B



HMC-500A



HMC-500B

- 500x500 Table
- 650x560x560mm Travel
- Index Table 1° / 0.001°
- 11/15KW Spindle motor
- Chain Type 40 Tool ATC
- ISO40 Spindle Taper (Gear Drives)
- X,Y, Z axes rapid traverse 30/30/24 M/m

HYDRAULIC BALANCE SYSTEM

- The Y-axis movement is counter balanced through a hydraulic cylinder.
An accumulator is equipped in the hydraulic circuit.
This counter balance system will reduce spindle head vibration to a minimum, while significantly improving machining accuracy.

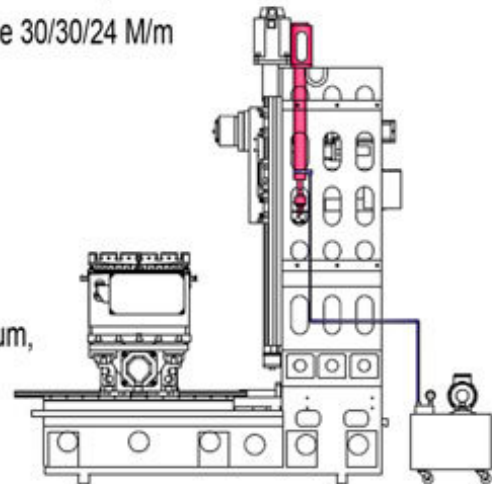

- Swing type automatic pallet change features stable construction and smooth change motion.
- Pallet change is fast - accomplished in only 8 seconds.
- Pallet positions on oversized cones taht guarantee high positioning accuracy.
- Max. pallet loading capacity is 400 kg.



AUTOMATIC PALLET CHANGE



WORK RANGE



GEAR BOX

- The spindle running is through a gear box, making the machine excellent for heavy cutting applications..

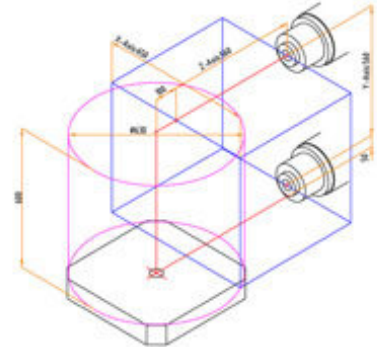

FLOOR SPACE

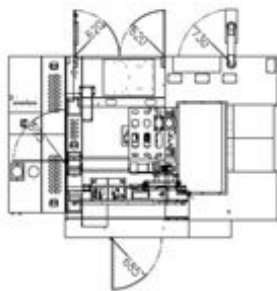

HMC-500A

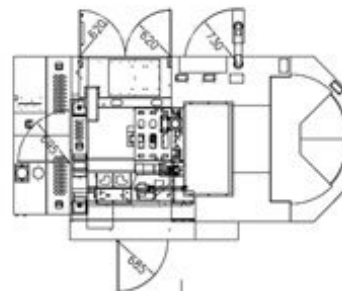

HMC-500B

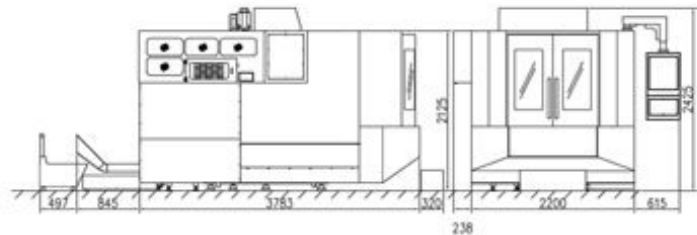
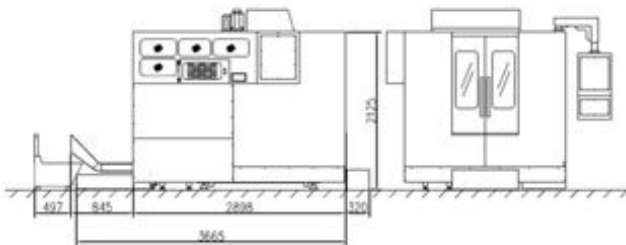

HMC-500A

HMC-500B

TABLE SIZE

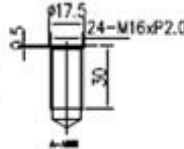
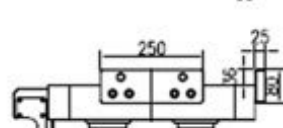
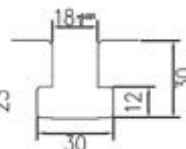
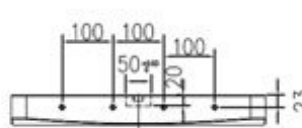
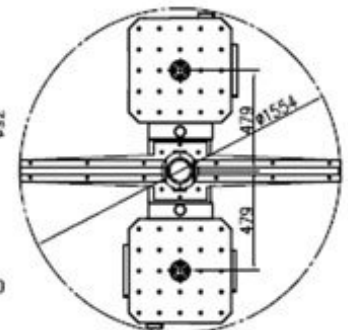
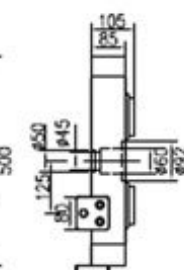
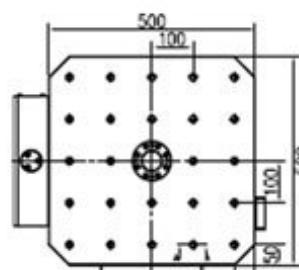
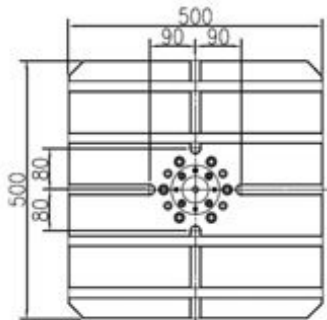

SPECIFICATIONS

MODEL	DESCRIPTION	HMC-500A	HMC-500B
TABLE	Table Size & Number (mm)	500 x 500	500 x 500 x 2
	Screw Size (Size x Pitch)	M16 x 2	M16 x 2
	Max. Loading Capacity	400kgs	
	Table Index (deg)	1°/0.001°(OPT.)	0.001°/1°(OPT.)
TRAVEL	Travel Range of X/Y/Z Axes	650/560/560	
	Spindle Center to Table Surface	50-610	
	Spindle Nose to Table Center	100-660	
SPINDLE	Spindle Taper	ISO40	
	Spindle speed	40-8000rpm (2 steps gear)	
	Spindle drive motor(Con./30min)	11/15kw	
FEED	Cutting Feed Rate of X/Y/Z axes	1-10000mm/min	
	Rapid Feed Rate of X/Y/Z axes	30/30/24m/min	
	X/YAxis Motors	2.5/2.5kw	
	Z Axis Motor	2.5kw	
	B Axis Motor	2.5kw	
ATC	Tool Shank Type	BT40, CAT40	
	Tool Capacity	40pcs	
	Max. Tool Diameter	Ø76mm	
	Max. Tool Length	300mm	
	Max. Tool Weight	8kgs	
MISCELLANEOUS	Powe Requirement	40KVA	
	Pneumatic Requirement	6kg/cm ²	
	Floor Space (LxWxH mm)	3055x4560x2425	3055x5445x2425
	Machine Weight	6500kgs	6700kgs

※THE SPECIFICATIONS ARE SUBJECT TO CHANGE WITHOUT PRIOR NOTICE.

■ STANDARD ACCESSORIES:

1. Spindle oil chiller
2. Air balst through spindle.
3. Flushing system.
4. 3 axes telescopic cover.
5. Coolant system.
6. Automatic lubrication system.
7. Build in twin screw type chip conveyor
8. Heat exchanger.
9. RS-232C interface.
10. Leveling bolt and pad.
11. Tool kit.

■ OPTIONS:

1. Coolant through spindle.
2. Linear scales for X/Y/Z axes.
3. Tool presetter.
4. External chain type chip
5. Transformer.

CNC-TAKANG CO., LTD.

No. 72, Alley 7, Lane 98, 1st Road,
 Taichung Industry Park, Taichung, TAIWAN
 FAX: +886-4-2359 6064 E-mail: takang@ms17.hinet.net
 TEL: (04)2359 6056 Web site: www.cnctakang.com.tw

CATA 0202